

Confocal Fabry-Perot Cavity

Seung-Hyun Lee
SUNY at Stony Brook
Optics Rotation Project for Fall 2001
Advisors: Professor, Harold Metcalf

INTRODUCTION

We report here the method to lock a confocal Fabry-Perot cavity's resonance frequency to the diode laser's frequency.

FABRY-PEROT

The Fabry-Perot interferometer is a very simple device that relies on the interference of multiple beams. It consists of two partially transmitting mirrors that are precisely aligned to form a reflective cavity. Incident light enters the Fabry-Perot cavity and undergoes multiple reflections between the mirrors so that the light can interfere with itself many times. If the frequency of the incident light is such that constructive interference occurs within the Fabry-Perot cavity, the light will be transmitted. Otherwise, destructive interference will not allow any light through the Fabry-Perot interferometer.

The condition for constructive interference within a Fabry-Perot interferometer is that the light forms a standing wave between the two mirrors. In other words, the optical distance between the two mirrors must equal an integral number of half wavelengths of the incident light. The constructive interference condition is therefore defined by the equation:

$$nd \cos \Theta = \frac{m\lambda}{2}$$

where m is an integer termed the order of interference, n is the refractive index of the medium between the two mirrors, d is the mirror separation, and Θ is the inclination of the direction of the incoming radiation to the normal of the mirrors.

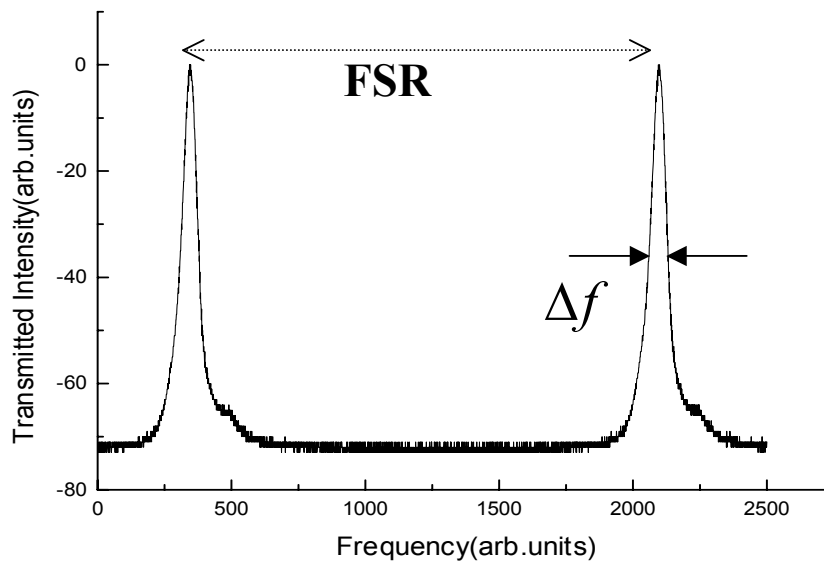

Free Spectral Range

The difference in frequency between consecutive interference fringes is defined as the free spectral range (FSR). It is a function of the physical mirror separation and is given by the following equation.

$$FSR = \frac{c}{4d} \quad (\text{for confocal F-P})$$

Finesse

Finesse is a factor given to quantify the performance of a Fabry-Perot interferometer. Conceptually, finesse can be thought of as the number of interfering beams within the Fabry-Perot cavity. A higher finesse value, indicating a greater number of interfering beams, results in a more complete interference process and therefore higher resolution measurements.

Minimum Resolvable Bandwidth

The minimum resolvable bandwidth or resolution, is the width (full width at half maximum peak intensity) of an interference fringe generated when a perfectly monochromatic light source is transmitted by a Fabry-Perot interferometer.

$$\Delta f = \frac{FSR}{finesse}$$

The highest possible resolution (smallest minimum resolvable bandwidth) is achieved when a Fabry-Perot interferometer has the smallest FSR and the highest finesse appropriate for the incident light source.

FREQUENCY-MODULATION & LOCK

The light emitted from a semiconductor diode laser is easily modulated by applying a small modulation to the injection current. If the laser frequency ω is modulated at the frequency Ω (sometimes called “dithering”), and the modulated phase of laser output is slowly varying compared to the unmodulated phase change ωt , then the modulated phase for the pure sinusoidal modulation can be written

$$\Phi(t) = \beta \sin(\Omega t)$$

where β is the modulation index, gives the peak phase excursion induced by the modulation. If we note that the instantaneous optical frequency is given by the instantaneous rate-of-change of the total phase, we have

$$\omega_{inst} = \omega + d\Phi / dt = \omega + \beta\Omega \cos(\Omega t)$$

Note that $\beta = \frac{\Delta\omega}{\Omega}$ is equal to the ratio of the maximum frequency excursion to the modulation frequency.
($\Delta\omega$: the maximum frequency excursion)

Often one would like to lock to the peak of a resonance feature, such as at the peak in cavity transmission, which gives a voltage signal with

$$\left. \frac{dV}{d\omega} \right|_{\omega_0} = 0$$

If we dither the laser frequency slowly at a frequency Ω , then

$$V(t) = V(\omega(t)) \approx V[\omega_{center} + \Delta\omega \cos(\Omega t)],$$

with $\beta \gg 1$, $V(t)$ behaves as if the laser frequency were slowly oscillating back and forth.

A lock-in amplifier with reference frequency Ω produces an error signal $\varepsilon(\omega)$, which is the Fourier component of $V(t)$ at frequency Ω . It is easily seen that on resonance we have $\varepsilon(\omega_0) = 0$, and for small dither amplitudes $d\varepsilon/d\omega(\omega_0) \neq 0$; thus this error signal can be used in a feedback loop to lock the laser frequency at ω_0 .

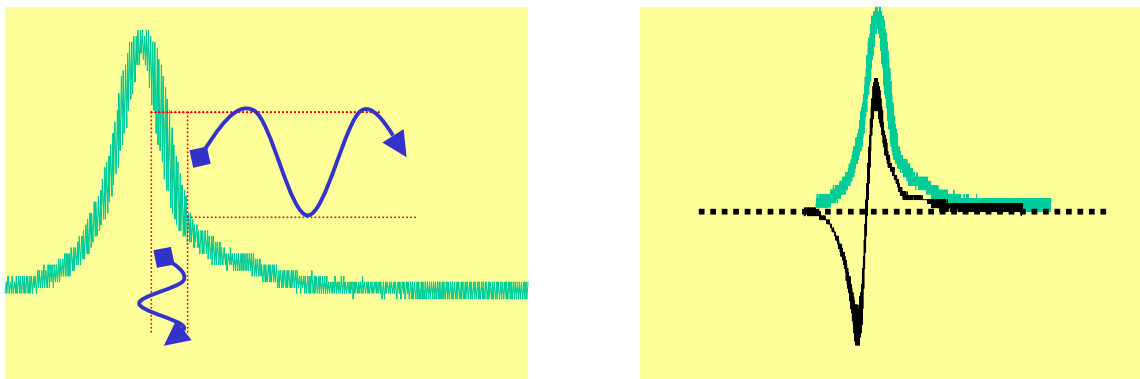

EXPERIMENT

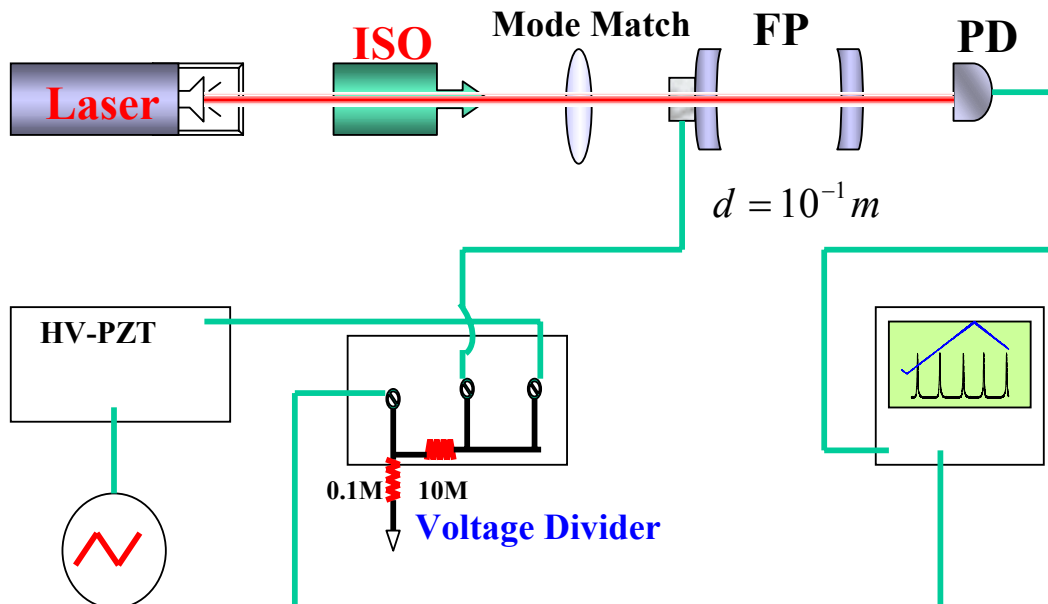

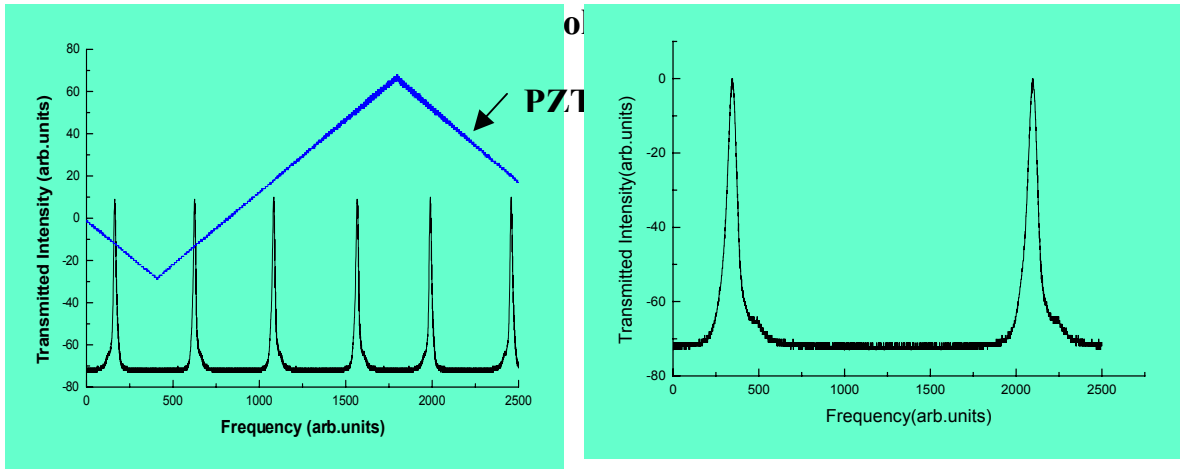

$$FSR = 0.75\text{GHz} \quad \Delta f = 29\text{MHz} \quad Finesse = 26$$

$$V_{p-p}(PZT) = 776\text{Volt}$$

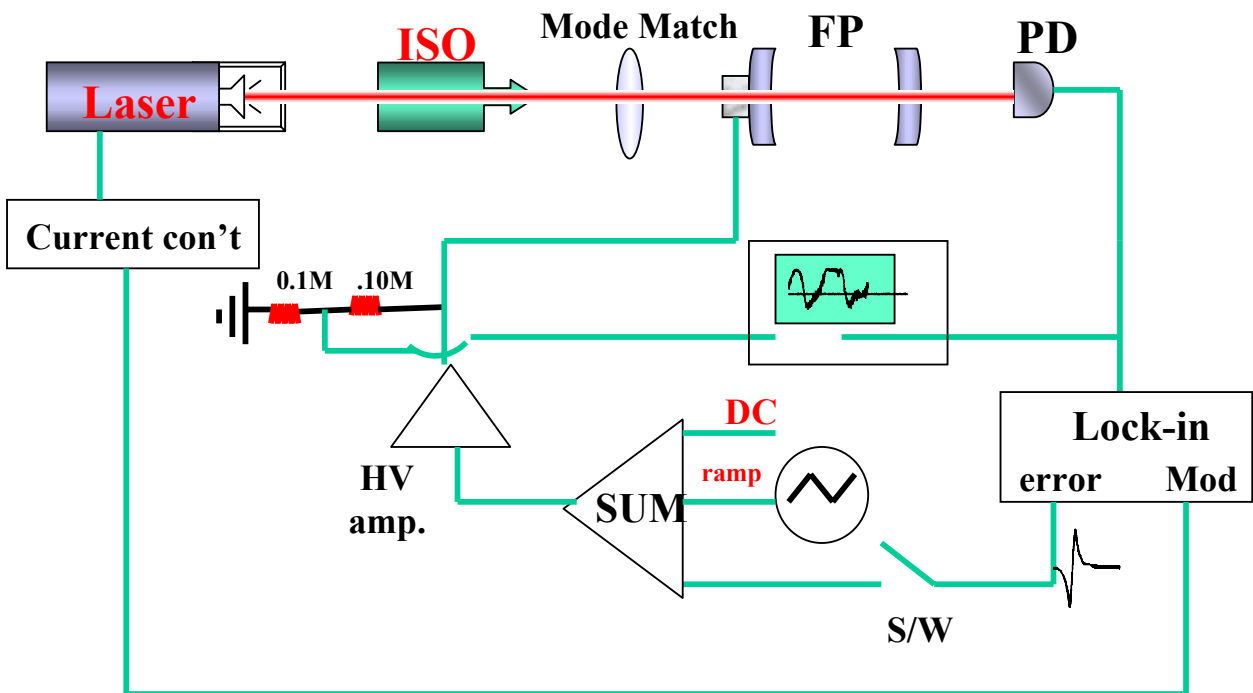

In order to scan the PZT and hence the cavity length, the signal from the photodiode should be first sent not only to the lock-in amp, but also to an oscilloscope for viewing.

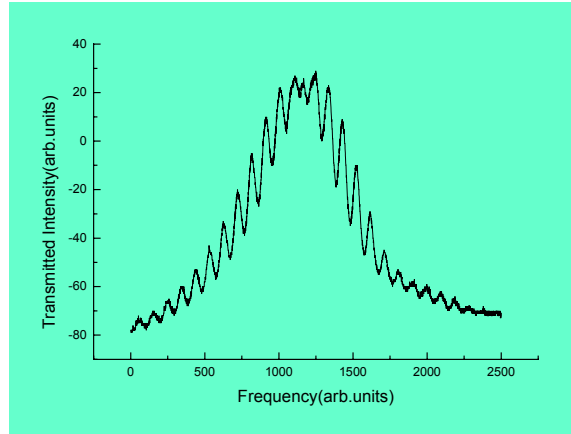
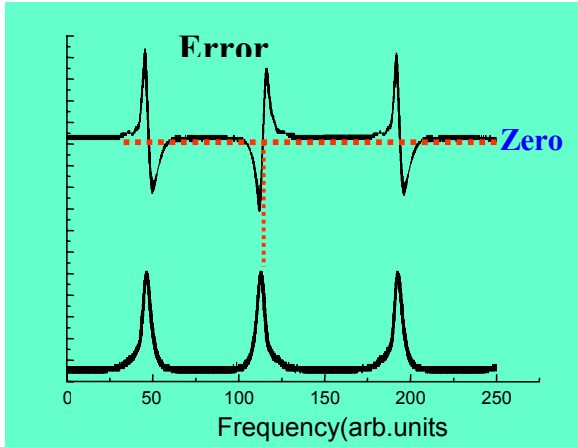

phase = 58°, time - const. = 3ms, current mod. at 5.3kHz

The error signal from the lock-in amplifier is equal to zero at the resonance peak.

To lock to the cavity to the laser, one should have the photodiode signal and the error signal on the same oscilloscope. The ramp should be set to the off position causing the spectrum seen via the photodiode to be replaced with a flat line and the lock s/w should be on, causing the line to stay at the resonance peak. The value it stays at is the frequency it is locked on.

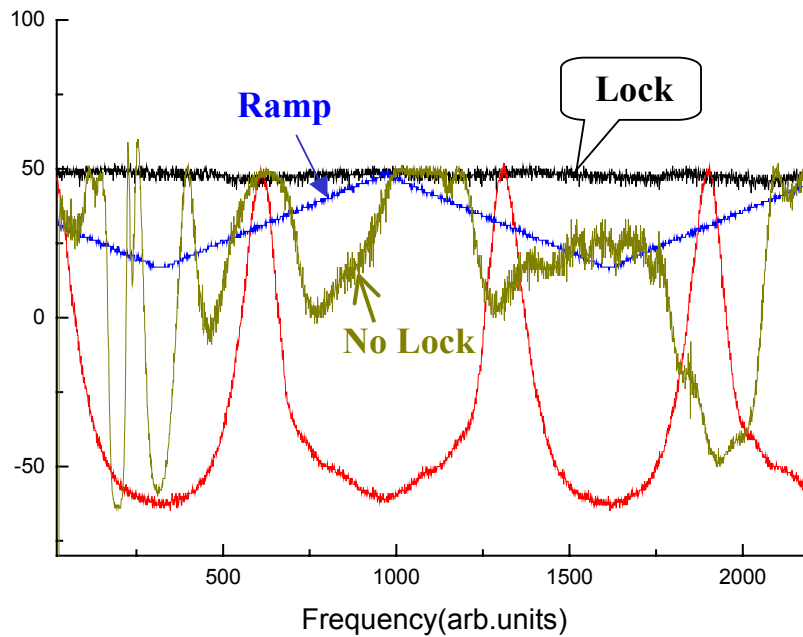

CONCLUSION

In the present work, we locked a confocal Fabry-Perot cavity resonance frequency to the diode's laser's frequency. The purpose of this experiment is to get a frequency reference for a transition ($3P \Rightarrow Rydberg$) of He-atoms. So, we need to combine this technique to the method which locks laser frequency to a *Rb* saturation spectrum.

ACKNOWLEDGEMENTS

I wish to thank Prof. Harold Metcalf, Matt. Cashen, Matt. Partlor, Benjamin, and our all group members for their useful help at various stages in this experiment. They so willingly gave me the encouragement and support. Had it not been for them, I should not get a good result.

REFERENCES

1. PH.Laurent, A.Clairon, and CH.Brent, "Frequency Noise Analysis of Optically Self-Locked Diode Lasers," IEEE J.Quantum Electrom., Vol.25, No.6, pp 1131-1141, 1989
2. B.Dahmani, L.Hollberg, and R.Drullinger, "Frequency stabilization of semiconductor lasers by resonant optical feedback," Optics Lett., Vol.12, No.11, pp 876-878, 1987
3. R.A.Boyd, J.L.Bliss, and K.G.Libbrecht, "Teaching Phycs with 670-nm Diode Lasers-Experiments with Fabry-Perot Cavites," Am.J.Phys., Vol.64, No.9, Sep.,1996